

Engine Powered Forklift

7FGF/7FDF and 7FG/7FD

1.5 to 5.0 ton

Series

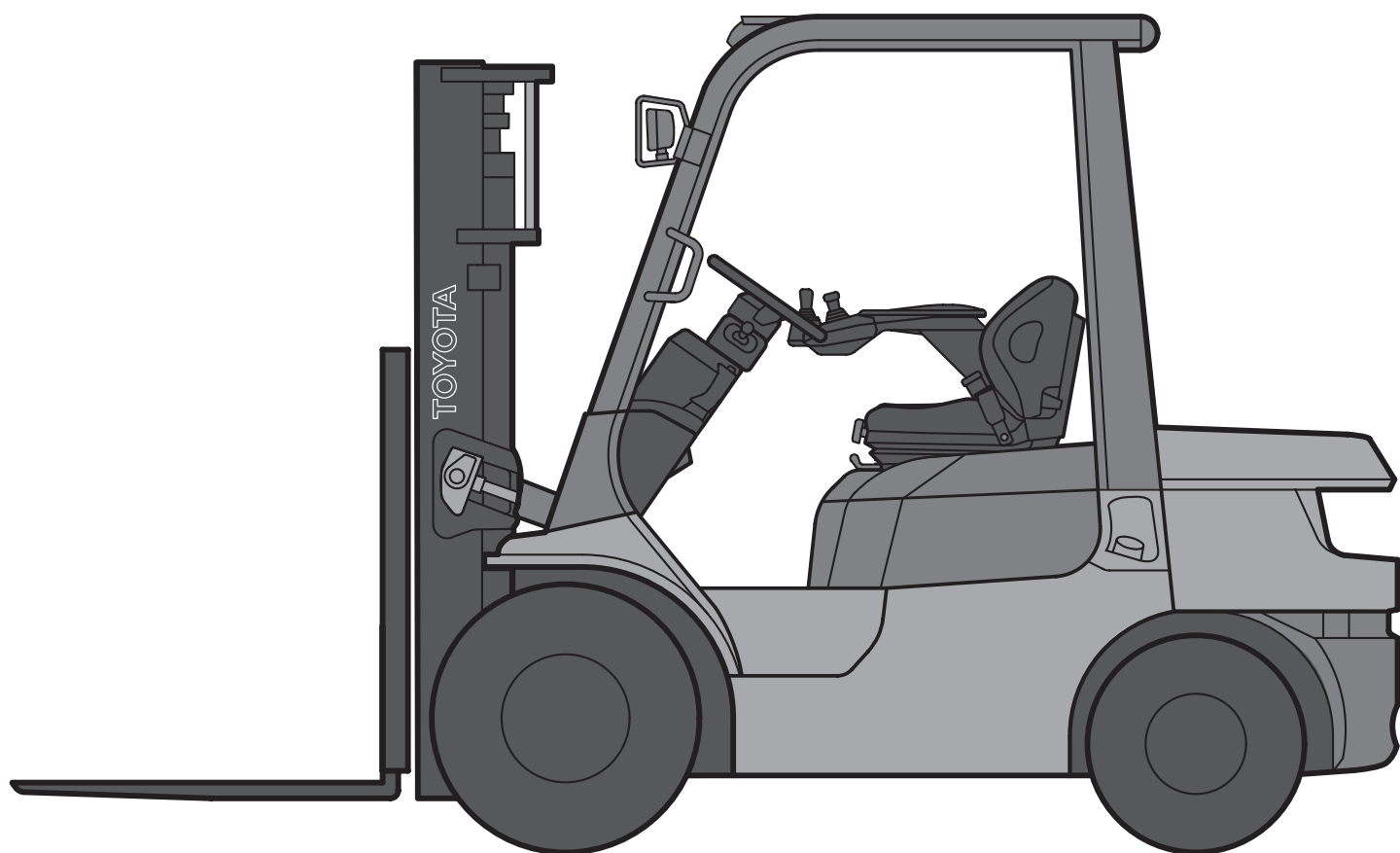

1,500 - 1,750 kg

MAIN VEHICLE SPECIFICATIONS

				TOYOTA	TOYOTA	TOYOTA	TOYOTA	
Characteristics	1.1	Manufacturer		TOYOTA	TOYOTA	TOYOTA	TOYOTA	
	1.2	Model		42-7FGF15	02-7FDF15	42-7FGF18	02-7FDF18	
	1.3	Power		LPG	diesel	LPG	diesel	
	1.4	Operator Type		rider seated	rider seated	rider seated	rider seated	
	1.5	Load capacity/rated load	Q	kg	1500	1500	1750	1750
	1.6	Load centre	c	mm	500	500	500	500
	1.8	Load distance, centre of drive axle to fork	x	mm	410	410	410	410
	1.9	Wheelbase	y	mm	1410	1410	1410	1410
	Weight	2.1	Truck weight ¹⁾		kg	2640	2710	2770
2.2		Axle loadings, laden front/rear		kg	3630/510	3660/550	4000/520	4030/560
2.3		Axle loadings, unladen front/rear		kg	1170/1470	1200/1510	1130/1640	1160/1680
Tyres, chassis	3.1	Tyres - pneumatic (P), pneumatic shaped cushion (SE), solid rubber (R)			P	P	P	P
	3.2	Tyre size - front			6.50-10-10PR (I)	6.50-10-10PR (I)	6.50-10-10PR (I)	6.50-10-10PR (I)
	3.3	Tyre size - rear			5.00-8-8PR (I)	5.00-8-8PR (I)	5.00-8-8PR (I)	5.00-8-8PR (I)
	3.5	Wheels - number front/rear (x = driven wheels)			2x/2	2x/2	2x/2	2x/2
	3.6	Tread - front	b ₁₀	mm	890	890	890	890
	3.7	Tread - rear	b ₁₁	mm	895	895	895	895
	Dimensions	4.1	Tilt of mast/fork carriage forward/backward	α/β	deg	6/10	6/10	6/10
4.2		Height, mast lowered	h ₁	mm	1995	1995	1995	1995
4.3		Free lift	h ₂	mm	150	150	150	150
4.4		Lift	h ₃	mm	3000	3000	3000	3000
4.5		Height, mast extended	h ₄	mm	4220	4220	4220	4220
4.7		Height of overhead guard	h ₆	mm	2080	2080	2080	2080
4.8		Seat height	h ₇	mm	1020	1020	1020	1020
4.12		Coupling height	h ₁₀	mm	280	280	280	280
4.19		Overall length	l ₁	mm	3250	3250	3280	3280
4.20		Length to face of forks	l ₂	mm	2250	2250	2280	2280
4.21		Overall width	b ₁	mm	1070	1070	1070	1070
4.22		Fork dimensions	s/e/l	mm	40/80/1000	40/80/1000	40/80/1000	40/80/1000
4.23		Fork carriage DIN 15 173, class/type A,B			II	II	II	II
4.24		Fork carriage width	b ₃	mm	920	920	920	920
4.31		Ground clearance, laden, below mast	m ₁	mm	115	115	115	115
4.32		Ground clearance, centre of wheelbase	m ₂	mm	135	135	135	135
4.33		Aisle width for pallets 1000x1200 wide*	A _{st}	mm	3570	3570	3590	3590
4.34	Aisle width for pallets 800x1200 long*	A _{st}	mm	3770	3770	3790	3790	
4.35	Turning radius	W _a	mm	1960	1960	1980	1980	
4.36	Internal turning radius	b ₁₃	mm	570	570	570	570	
Performance	5.1	Travel speed, laden/unladen		km/h	18.5/19	19/19.5	18.5/19	19/19.5
	5.2	Lift speed, laden/unladen		m/s	0.60/0.64	0.65/0.67	0.60/0.64	0.65/0.67
	5.3	Lowering speed, laden/unladen		m/s	0.50/0.55	0.50/0.55	0.50/0.55	0.50/0.55
	5.6	Max. drawbar pull, laden/unladen		N	17500/6300	17500/6800	17500/6300	17500/6300
	5.7	Gradeability, laden ²⁾		%	41	42	36	38
	5.8	Max. gradeability, laden/unladen ²⁾		%	45/22	45/22	41/20	42/20
	5.9	Acceleration time, laden/unladen		s				
5.10	Service brake				hydraulic	hydraulic	hydraulic	
Engine	7.1	Engine manufacturer/type			TOYOTA 4Y	TOYOTA 1DZ-II	TOYOTA 4Y	TOYOTA 1DZ-II
	7.2	Engine power acc to ISO 1585		kW	37	40	37	40
	7.3	Rated speed		1/min	2400	2400	2400	2400
	7.4	No. of cylinders/displacement		cm ³	4/2237	4/2486	4/2237	4/2486
	7.5	Fuel consumption acc to VDI cycle		l/h				
Others	8.2	Operating pressure for attachments		bar	118	118	118	118
	8.3	Oil volume for attachments		l/min	56	58	56	58
	8.4	Sound level at the driver's ear according to EN 12 053		dB(A)	78	81	78	81
	8.5	Towing coupling, type DIN						

* aisle width calculation based on VDI 2198

¹⁾ At 1,5km/h

²⁾ Computed values

7FG/DF15, 7FG/DF18

DIMENSIONAL DRAWINGS

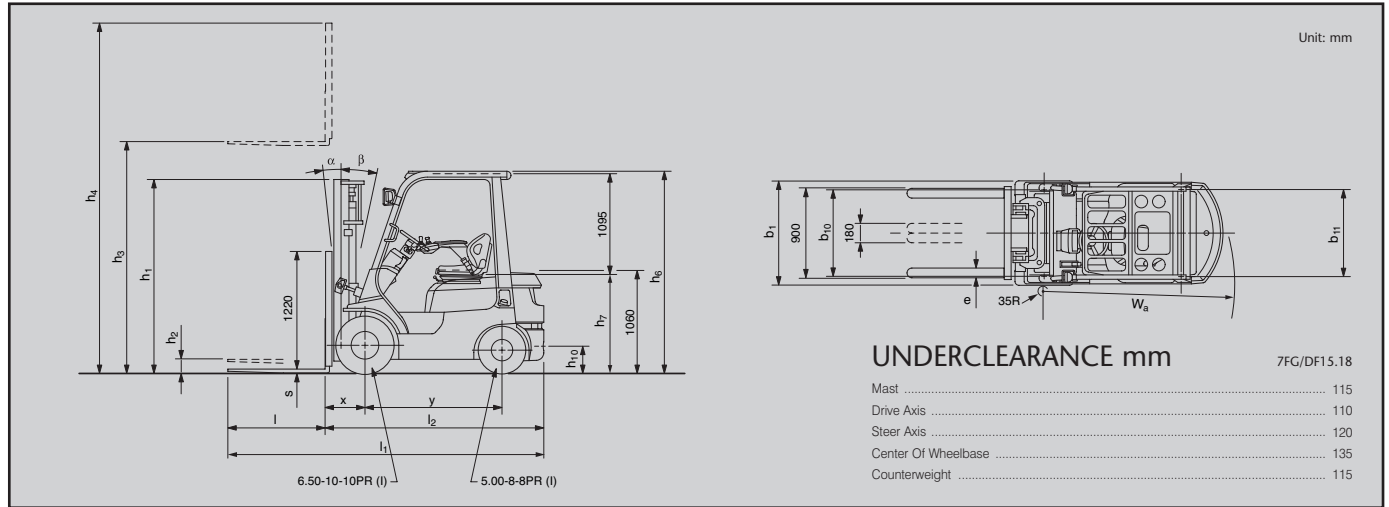

SPECIAL TREAD

Model	7FGF/7FDF15.18	
Front Tyre Single/Dual	Single	Dual
Front Tyre Size	6.50-10-10PR (I)	6.00-9-10PR (I)
Overall Width	mm 1070	1430
Tread, Front	mm 890	1085

MAST SPECIFICATION & RATED CAPACITIES

Model	Mast Type	Maximum Fork Height h_3	Overall Height			Free Lift		Single Tyre			Dual Tyre	
			Lowered h_1	Extended Without Load Backrest h_4	Without Load Backrest h_2	With Standard Load Backrest h_2	Tilt Range		Load Capacity at 500 mm LC	Tilt Range		Load Capacity at 500 mm LC
							FWD	BWD		FWD	BWD	
mm	mm	mm	mm	mm	mm	deg	deg	kg	deg	deg	kg	
7FG/DF15	V	3000	1995	3605	150	150	6	10	1500	7	9	1500
		3300	2145	3905	150	150	6	10	1500	7	9	1500
		3500	2245	4105	150	150	6	10	1500	7	9	1500
		3700	2405	4305	150	150	6	10	1500	7	9	1500
		4000	2595	4605	150	150	6	10	1500	7	9	1500
		4500	2845	5105	150	150	6	6	1450	7	9	1450
	FV	5000	3095	5605	150	150	6	6	1300	7	5	1350
		3000	1995	3560	1410 [1150]	780	6	10 (6)	1500	7	9	1500
		3300	2145	3860	1560 [1300]	930	6	10 (6)	1500	7	9	1500
		3500	2245	4060	1660 [1400]	1030	6	10 (6)	1500	7	9	1500
		3700	2405	4260	1820 [1560]	1190	6	10 (6)	1500	7	9	1500
		4000	2595	4560	2010 [1750]	1380	6	10 (6)	1500	7	9	1500
	FSV	3700	1795	4235	1260 [1190]	580	6	6	1400	7	5	1400
		4000	1895	4535	1360 [1290]	680	6	6	1400	7	5	1400
		4300	1995	4835	1460 [1390]	780	6	6	1400	7	5	1400
		4700	2145	5235	1610 [1540]	930	6	6	1350	7	5	1350
		5000	2245	5535	1710 [1640]	1030	6	6	1250	7	5	1300
		5500	2405	6035	1870 [1800]	1190	6	6	950	7	5	1250
7FG/DF18	V	6000	2595	6535	2060 [1990]	1380	6	6	700	7	5	1100
		6500	2845	6785	2310	1630	-	-	-	7	5	900
		3000	1995	3560	1410 [1150]	780	6	10 (6)	1750	7	9	1750
		3300	2145	3860	1560 [1300]	930	6	10 (6)	1750	7	9	1750
		3500	2245	4060	1660 [1400]	1030	6	10 (6)	1750	7	9	1750
		3700	2405	4260	1820 [1560]	1190	6	10 (6)	1750	7	9	1750
	FV	4000	2595	4560	2010 [1750]	1380	6	10 (6)	1650	7	9	1650
		3000	1995	3560	1410 [1150]	780	6	10 (6)	1750	7	9	1750
		3300	2145	3860	1560 [1300]	930	6	10 (6)	1750	7	9	1750
		3500	2245	4060	1660 [1400]	1030	6	10 (6)	1750	7	9	1750
		3700	2405	4260	1820 [1560]	1190	6	10 (6)	1750	7	9	1750
		4000	2595	4560	2010 [1750]	1380	6	10 (6)	1650	7	9	1650
	FSV	3700	1795	4235	1260 [1190]	580	6	6	1600	7	5	1600
		4000	1895	4535	1360 [1290]	680	6	6	1600	7	5	1600
		4300	1995	4835	1460 [1390]	780	6	6	1550	7	5	1550
		4700	2145	5235	1610 [1540]	930	6	6	1500	7	5	1500
		5000	2245	5535	1710 [1640]	1030	6	6	1450	7	5	1450
		5500	2405	6035	1870 [1800]	1190	6	6	1100	7	5	1400
FSV	6000	2595	6535	2060 [1990]	1380	6	6	850	7	5	1200	
	6500	2845	6785	2310	1630	-	-	-	7	5	850	

Note: Height of standard load backrest is 1220 mm; h_4 with standard load backrest is + 615 mm (V), + 660 mm (FV), + 685 mm (FSV)
 Data between "[]" is for when 'A4 piping' is selected
 Data between "()" is for when 'Steel cab' or 'Cab without doors' is selected

2,000 - 2,500 kg

MAIN VEHICLE SPECIFICATIONS

				TOYOTA	TOYOTA	TOYOTA	TOYOTA	TOYOTA	TOYOTA		
Characteristics	1.1	Manufacturer		TOYOTA	TOYOTA	TOYOTA	TOYOTA	TOYOTA	TOYOTA		
	1.2	Model		42-7FGF20	02-7FDF20	62-7FDF20	42-7FGF25	02-7FDF25	62-7FDF25		
	1.3	Power		LPG	diesel	diesel	LPG	diesel	diesel		
	1.4	Operator Type		rider seated	rider seated	rider seated	rider seated	rider seated	rider seated		
	1.5	Load capacity/rated load	Q	kg	2000	2000	2000	2500	2500	2500	
	1.6	Load centre	c	mm	500	500	500	500	500	500	
	1.8	Load distance, centre of drive axle to fork	x	mm	470	470	470	470	470	470	
	1.9	Wheelbase	y	mm	1600	1600	1600	1600	1600	1600	
	Weight	2.1	Truck weight ¹⁾		kg	3450	3560	3520	3770	3880	3840
2.2		Axle loadings, laden front/rear		kg	4740/710	4780/780	4770/750	5490/780	5530/850	5520/820	
2.3		Axle loadings, unladen front/rear		kg	1540/1910	1580/1980	1570/1950	1470/2300	1510/2370	1500/2340	
Tyres, chassis	3.1	Tyres - pneumatic (P), pneumatic shaped cushion (SE), solid rubber (R)			P	P	P	P	P	P	
	3.2	Tyre size - front			7.00-12-12PR (I)	7.00-12-12PR (I)	7.00-12-12PR (I)	7.00-12-12PR (I)	7.00-12-12PR (I)	7.00-12-12PR (I)	
	3.3	Tyre size - rear			6.00-9-10PR (I)	6.00-9-10PR (I)	6.00-9-10PR (I)	6.00-9-10PR (I)	6.00-9-10PR (I)	6.00-9-10PR (I)	
	3.5	Wheels - number front/rear (x = driven wheels)			2x/2	2x/2	2x/2	2x/2	2x/2	2x/2	
	3.6	Tread - front	b ₁₀	mm	960	960	960	960	960	960	
	3.7	Tread - rear	b ₁₁	mm	965	965	965	965	965	965	
	Dimensions	4.1	Tilt of mast/fork carriage forward/backward		α/β	deg	6/10	6/10	6/10	6/10	6/10
4.2		Height, mast lowered		h ₁	mm	1995	1995	1995	1995	1995	
4.3		Free lift		h ₂	mm	150	150	150	150	150	
4.4		Lift		h ₃	mm	3000	3000	3000	3000	3000	
4.5		Height, mast extended		h ₄	mm	4220	4220	4220	4220	4220	
4.7		Height of overhead guard		h ₆	mm	2110	2110	2110	2110	2110	
4.8		Seat height		h ₇	mm	1055	1055	1055	1055	1055	
4.12		Coupling height		h ₁₀	mm	310	310	310	310	310	
4.19		Overall length		l ₁	mm	3545	3545	3545	3600	3600	3600
4.20		Length to face of forks		l ₂	mm	2545	2545	2545	2600	2600	2600
4.21		Overall width		b ₁	mm	1150	1150	1150	1150	1150	1150
4.22		Fork dimensions		s/e/l	mm	40/100/1000	40/100/1000	40/100/1000	40/100/1000	40/100/1000	40/100/1000
4.23		Fork carriage DIN 15 173, class/type A,B				II	II	II	II	II	II
4.24		Fork carriage width		b ₃	mm	1020	1020	1020	1020	1020	1020
4.31		Ground clearance, laden, below mast		m ₁	mm	120	120	120	120	120	120
4.32		Ground clearance, centre of wheelbase		m ₂	mm	170	170	170	170	170	170
4.33		Aisle width for pallets 1000x1200 wide*		A _{st}	mm	3840	3840	3840	3910	3910	3910
4.34	Aisle width for pallets 800x1200 long*		A _{sl}	mm	4040	4040	4040	4110	4110	4110	
4.35	Turning radius		W _a	mm	2170	2170	2170	2240	2240	2240	
4.36	Internal turning radius		b ₁₃	mm	725	725	725	725	725	725	
Performance	5.1	Travel speed, laden/unladen		km/h	17.5/18	19/19.5	19/19.5	17.5/18	19/19.5	19/19.5	
	5.2	Lift speed, laden/unladen		m/s	0.60/0.64	0.65/0.67	0.61/0.64	0.60/0.64	0.65/0.67	0.61/0.64	
	5.3	Lowering speed, laden/unladen		m/s	0.50/0.50	0.50/0.50	0.50/0.50	0.50/0.50	0.50/0.50	0.50/0.50	
	5.6	Max. drawbar pull, laden/unladen		N	18500/8800	20000/8800	17500/8800	18500/8300	20000/8300	17500/8300	
	5.7	Gradeability, laden ¹⁾		%	32	34	30	26	29	25	
	5.8	Max. gradeability, laden/unladen ²⁾		%	36/22	38/22	38/22	30/19	32/19	32/19	
	5.9	Acceleration time, laden/unladen		s							
5.10	Service brake				hydraulic	hydraulic	hydraulic	hydraulic	hydraulic		
Engine	7.1	Engine manufacturer/type			TOYOTA 4Y	TOYOTA 2Z	TOYOTA 1DZ-II	TOYOTA 4Y	TOYOTA 2Z	TOYOTA 1DZ-II	
	7.2	Engine power acc to ISO 1585		kW	37	42	44	37	42	44	
	7.3	Rated speed		1/min	2400	2200	2600	2400	2200	2600	
	7.4	No. of cylinders/displacement		cm ³	4/2237	4/3469	4/2486	4/2237	4/3469	4/2486	
	7.5	Fuel consumption acc to VDI cycle		l/h							
Others	8.2	Operating pressure for attachments		bar	147	147	147	147	147	147	
	8.3	Oil volume for attachments		l/min	72	76	69	72	76	69	
	8.4	Sound level at the driver's ear according to EN 12 053		dB(A)	78	81	81	78	81	81	
	8.5	Towing coupling, type DIN									

* aisle width calculation based on VDI 2198

¹⁾ At 1,5km/h

²⁾ Computed values

DIMENSIONAL DRAWINGS

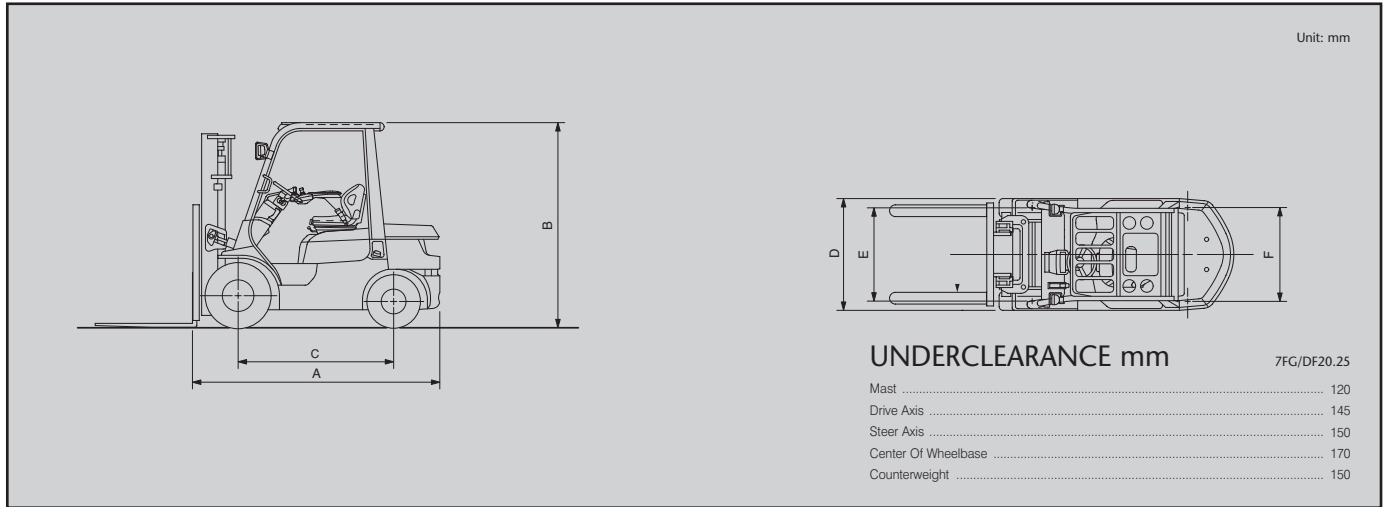

SPECIAL TREAD

Model	7FGF/7FDF20,25	
Front Tyre Single/Dual	Single	Dual
Front Tyre Size	7.00-12-12PR (I)	7.00-12-12PR (I)
Overall Width	mm 1150	mm 1610
Tread, Front	mm 960	mm 1190

MAST SPECIFICATION & RATED CAPACITIES

Model	Mast Type	Maximum Fork Height h_3	Overall Height		Free Lift		Single Tyre			Dual Tyre		
			Lowered h_1	Extended Without Load Backrest h_4	Without Load Backrest h_2	With Standard Load Backrest h_2	Tilt Range		Load Capacity at 500 mm LC	Tilt Range		Load Capacity at 500 mm LC
							FWD	BWD		FWD	BWD	
		mm	mm	mm	mm	deg	deg	kg	deg	deg	kg	
7FG/DF20	V	3000	1995	3650	150	150	6	10	2000	6	10	2000
		3300	2145	3950	150	150	6	10	2000	6	10	2000
		3500	2245	4150	150	150	6	10	2000	6	10	2000
		3700	2405	4350	150	150	6	10	2000	6	10	2000
		4000	2595	4650	150	150	6	10	2000	6	10	2000
		4500	2845	5150	150	150	6	6	1950	6	10	1950
	FV	5000	3095	5650	150	150	6	6	1850	6	6	1900
		3000	1995	3590	1400 [1180]	775	6	10	2000	6	10	2000
		3300	2145	3890	1550 [1330]	925	6	10	2000	6	10	2000
		3500	2245	4090	1650 [1430]	1025	6	10	2000	6	10	2000
		3700	2405	4290	1810 [1590]	1185	6	10	2000	6	10	2000
		4000	2595	4590	2000 [1780]	1375	6	10	2000	6	10	2000
	FSV	3700	1795	4250	1225 [1190]	575	6	6	2000	6	6	2000
		4000	1895	4550	1325 [1290]	675	6	6	1950	6	6	1950
		4300	1995	4850	1425 [1390]	775	6	6	1900	6	6	1950
		4700	2145	5250	1575 [1540]	925	6	6	1850	6	6	1900
		5000	2245	5550	1675 [1640]	1025	6	6	1450	6	6	1850
		5500	2405	6050	1835 [1800]	1185	6	6	1200	6	6	1800
7FG/DF25	V	6000	2595	6550	2025 [1990]	1375	6	6	850	6	6	1600
		6500	2845	7050	2275 [2240]	1625	-	-	-	6	6	1550
		3000	1995	3590	1400 [1180]	775	6	10	2500	6	10	2500
		3300	2145	3890	1550 [1330]	925	6	10	2500	6	10	2500
		3500	2245	4090	1650 [1430]	1025	6	10	2500	6	10	2500
		3700	2405	4290	1810 [1590]	1185	6	10	2500	6	10	2500
	FV	4000	2595	4590	2000 [1780]	1375	6	10	2500	6	10	2500
		3000	1995	3590	1400 [1180]	775	6	10	2500	6	10	2500
		3300	2145	3890	1550 [1330]	925	6	10	2500	6	10	2500
		3500	2245	4090	1650 [1430]	1025	6	10	2500	6	10	2500
		3700	2405	4290	1810 [1590]	1185	6	10	2500	6	10	2500
		4000	2595	4590	2000 [1780]	1375	6	10	2500	6	10	2500
	FSV	3700	1795	4250	1225 [1190]	575	6	6	2500	6	6	2500
		4000	1895	4550	1325 [1290]	675	6	6	2500	6	6	2500
		4300	1995	4850	1425 [1390]	775	6	6	2300	6	6	2500
		4700	2145	5250	1575 [1540]	925	6	6	2000	6	6	2450
		5000	2245	5550	1675 [1640]	1025	6	6	1500	6	6	2400
		5500	2405	6050	1835 [1800]	1185	6	6	1250	6	6	2050
FSV	6000	2595	6550	2025 [1990]	1375	6	6	900	6	6	1700	
	6500	2845	7050	2275 [2240]	1625	-	-	-	6	6	1550	

Note: Height of standard load backrest is 1220 mm; h_4 with standard load backrest is + 570 mm (V), + 630 mm (FV), + 670 mm (FSV)
Data between "[]" is for when 'A4 piping' is selected

3,000 - 3,500 kg

MAIN VEHICLE SPECIFICATIONS

				TOYOTA	TOYOTA	TOYOTA	TOYOTA	TOYOTA
Characteristics	1.1	Manufacturer				TOYOTA	TOYOTA	TOYOTA
	1.2	Model				02-7FGF30	02-7FDF30	62-7FDF30
	1.3	Power				LPG	diesel	diesel
	1.4	Operator Type				rider seated	rider seated	rider seated
	1.5	Load capacity/rated load	Q	kg	3000	3000	3000	3500
	1.6	Load centre	c	mm	500	500	500	500
	1.8	Load distance, centre of drive axle to fork	x	mm	485	485	485	495
	1.9	Wheelbase	y	mm	1700	1700	1700	1700
	Weight	2.1	Truck weight ¹⁾				kg	4340
2.2		Axle loadings, laden front/rear				kg	6430/910	6470/980
2.3		Axle loadings, unladen front/rear				kg	1690/2650	1740/2710
Tyres, chassis	3.1	Tyres - pneumatic (P), pneumatic shaped cushion (SE), solid rubber (R)					P	P
	3.2	Tyre size - front					28x9-15-12PR (I)	28x9-15-12PR (I)
	3.3	Tyre size - rear					6.50-10-10PR (I)	6.50-10-10PR (I)
	3.5	Wheels - number front/rear (x = driven wheels)					2x/2	2x/2
	3.6	Tread - front	b ₁₀	mm	1010	1010	1010	1060
	3.7	Tread - rear	b ₁₁	mm	965	965	965	965
	Dimensions	4.1	Tilt of mast/fork carriage forward/backward		α/β	deg	6/10	6/10
4.2		Height, mast lowered		h ₁	mm	2020	2020	2020
4.3		Free lift		h ₂	mm	135	135	135
4.4		Lift		h ₃	mm	3000	3000	3000
4.5		Height, mast extended		h ₄	mm	4220	4220	4220
4.7		Height of overhead guard		h ₆	mm	2170	2170	2170
4.8		Seat height		h ₇	mm	1110	1110	1110
4.12		Coupling height		h ₁₀	mm	335	335	335
4.19		Overall length		l ₁	mm	3745	3745	3745
4.20		Length to face of forks		l ₂	mm	2745	2745	2745
4.21		Overall width		b ₁	mm	1240	1240	1240
4.22		Fork dimensions		s/e/l	mm	45/100/1000	45/100/1000	45/100/1000
4.23		Fork carriage DIN 15 173, class/type A,B				III	III	III
4.24		Fork carriage width		b ₃	mm	1070	1070	1070
4.31		Ground clearance, laden, below mast		m ₁	mm	140	140	140
4.32		Ground clearance, centre of wheelbase		m ₂	mm	215	215	215
4.33		Aisle width for pallets 1000x1200 wide*		A _{st}	mm	4085	4085	4085
4.34	Aisle width for pallets 800x1200 long*		A _{st}	mm	4285	4285	4285	
4.35	Turning radius		W _a	mm	2400	2400	2400	
4.36	Internal turning radius		b ₁₃	mm	810	810	810	
Performance	5.1	Travel speed, laden/unladen			km/h	18.5/19	19/19.5	18.5/19
	5.2	Lift speed, laden/unladen			m/s	0.51/0.55	0.55/0.57	0.50/0.53
	5.3	Lowering speed, laden/unladen			m/s	0.50/0.50	0.50/0.50	0.50/0.50
	5.6	Max. drawbar pull, laden/unladen			N	18000/9800	19500/9800	18500/9800
	5.7	Gradeability, laden ²⁾			%	22	23	22
	5.8	Max. gradeability, laden/unladen ³⁾			%	25/19	26/19	25/19
	5.9	Acceleration time, laden/unladen			s			
5.10	Service brake				hydraulic	hydraulic	hydraulic	
Engine	7.1	Engine manufacturer/type				TOYOTA 4Y	TOYOTA 2Z	TOYOTA 1DZ-II
	7.2	Engine power acc to ISO 1585			kW	40	42	44
	7.3	Rated speed			1/min	2600	2200	2600
	7.4	No. of cylinders/displacement			cm ³	4/2237	4/3469	4/2486
	7.5	Fuel consumption acc to VDI cycle			l/h			
Others	8.2	Operating pressure for attachments			bar	147	147	147
	8.3	Oil volume for attachments			l/min	69	74	66
	8.4	Sound level at the driver's ear according to EN 12 053			dB(A)	78	81	81
	8.5	Towing coupling, type DIN						

* aisle width calculation based on VDI 2198

¹⁾ At 1,5km/h

²⁾ Computed values

DIMENSIONAL DRAWINGS

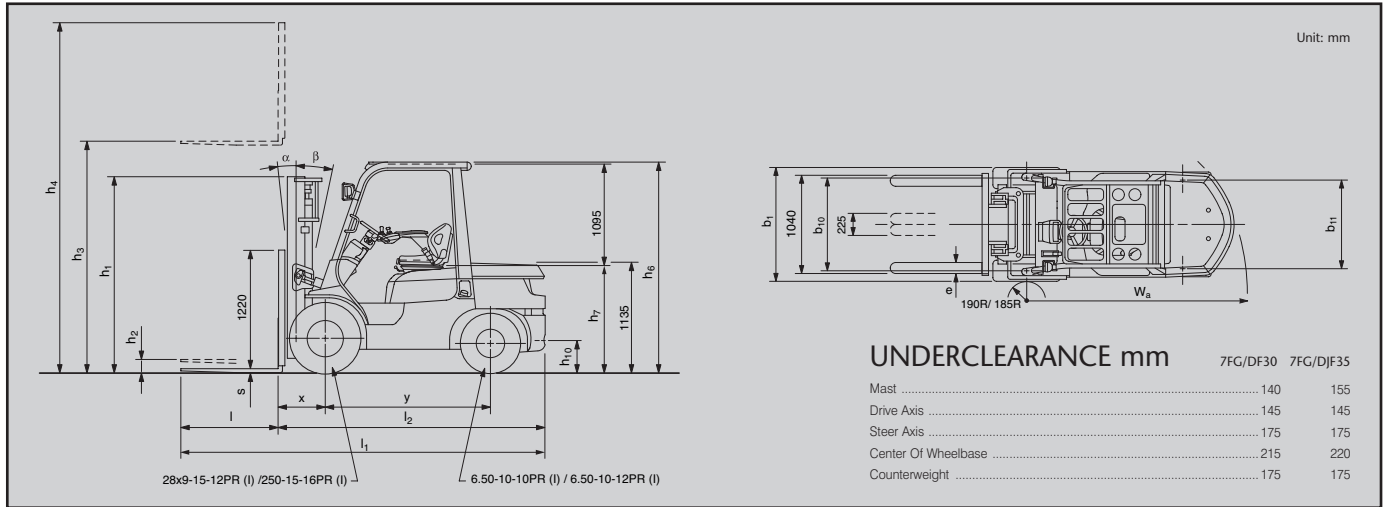

SPECIAL TREAD

Model	7FGF/7DF30		7FGJF/7DJF35	
Front Tyre Single/Dual	Dual	Dual	Dual	Dual
Front Tyre Size	28x9-15-12PR (I)	28x8-15-12PR (I)	250-15-16PR (I)	28x8-15-12PR (I)
Overall Width	1240	1675	1290	1715
Tread, Front	1010	1240	1060	1290

MAST SPECIFICATION & RATED CAPACITIES

Model	Mast Type	Maximum Fork Height h_3	Overall Height			Free Lift		Single Tyre			Dual Tyre		
			Lowered h_1	Extended Without Load Backrest h_4	Without Load Backrest h_2	With Standard Load Backrest h_2	Tilt Range		Load Capacity at 500 mm LC	Tilt Range		Load Capacity at 500 mm LC	
							FWD	BWD		FWD	BWD		
mm	mm	mm	mm	mm	mm	deg	deg	kg	deg	deg	kg		
7FG/DF30	V	3000	2020	3710	135	135	6	10	3000	6	10	3000	
		3300	2170	4010	135	135	6	10	3000	6	10	3000	
		3500	2270	4210	135	135	6	10	3000	6	10	3000	
		3700	2430	4410	135	135	6	10	3000	6	10	3000	
		4000	2620	4710	135	135	6	10	3000	6	10	3000	
		4500	2870	5210	135	135	6	6	3000	6	10	3000	
	5000	3120	5710	135	135	6	6	2600	6	6	3000		
	FV	3000	2020	3605	1400 [1130]	800	6	10	3000	6	10	3000	
		3300	2170	3905	1550 [1280]	950	6	10	3000	6	10	3000	
		3500	2270	4105	1650 [1380]	1050	6	10	3000	6	10	3000	
		3700	2430	4305	1810 [1540]	1210	6	10	3000	6	10	3000	
		4000	2620	4605	2000 [1730]	1400	6	10	3000	6	10	3000	
	FSV	3700	1920	4305	1305 [1100]	700	6	6	3000	6	6	3000	
		4000	2020	4605	1405 [1200]	800	6	6	3000	6	6	3000	
		4300	2170	4905	1555 [1350]	950	6	6	3000	6	6	3000	
		4700	2270	5305	1655 [1450]	1050	6	6	3000	6	6	3000	
		5000	2430	5605	1815 [1610]	1210	6	6	2600	6	6	2950	
		5500	2620	6105	2005 [1800]	1400	6	6	1900	6	6	2650	
		6000	2870	6605	2255 [2050]	1650	6	6	1500	6	6	2050	
		6500	3120	7105	2505 [2300]	1900	-	-	-	6	6	1600	
		7000	3370	7605	2755 [2550]	2150	-	-	-	6	6	1200	
7FG/DJF35		V	3000	2125	3865	135	135	6	10	3500	6	10	3500
	3300		2305	4165	135	135	6	10	3500	6	10	3500	
	3500		2405	4365	135	135	6	10	3500	6	10	3500	
	3700		2505	4565	135	135	6	10	3500	6	10	3500	
	4000		2755	4865	135	135	6	10	3500	6	10	3500	
	4500		3005	5365	135	135	6	6	3500	6	10	3500	
	5000	3255	5865	135	135	6	6	3300	6	6	3400		
	FV	3000	2125	3730	1395 [1110]	905	6	10	3500	6	10	3500	
		3300	2305	4030	1575 [1290]	1085	6	10	3500	6	10	3500	
		3500	2405	4230	1675 [1390]	1185	6	10	3500	6	10	3500	
		3700	2505	4430	1775 [1490]	1285	6	10	3500	6	10	3500	
		4000	2755	4730	2025 [1740]	1535	6	10	3500	6	10	3500	
	FSV	3700	2035	4430	1305	815	6	6	3500	6	6	3500	
		4000	2185	4730	1455	965	6	6	3500	6	6	3500	
		4300	2235	5030	1505	1015	6	6	3500	6	6	3500	
		4700	2445	5430	1715	1225	6	6	3400	6	6	3400	
		5000	2635	5730	1905	1415	6	6	3300	6	6	3300	
		5500	2885	6230	2155	1665	6	6	2700	6	6	3200	
		6000	3135	6730	2405	1915	6	6	2000	6	6	2400	
		6500	3385	7230	2655	2165	-	-	-	6	6	1650	
		7000	3635	7730	2905	2415	-	-	-	6	6	900	

Note: Height of standard load backrest is 1220 mm; h_4 with standard load backrest is + 510/ 355 mm (7FG/DF30/7FG/DJF35 V), + 615/490 mm (7FG/DF30/7FG/DJF35 FV and FSV).
Data between "[]" is for when 'A4 piping' is selected

3,500 kg, at 600 mm LCP

MAIN VEHICLE SPECIFICATIONS

Characteristics	1.1	Manufacturer			TOYOTA	TOYOTA	
	1.2	Model			02-7FG35	42-7FD35	
	1.3	Power			gasoline	diesel	
	1.4	Operator Type			rider seated	rider seated	
	1.5	Load capacity/rated load	Q	kg	4000 [3500]	4000 [3500]	
	1.6	Load centre	c	mm	500 [600]	500 [600]	
	1.8	Load distance, centre of drive axle to fork	x	mm	520	520	
	1.9	Wheelbase	y	mm	1840	1840	
	Weight	2.1	Truck weight ¹⁾		kg	5650	5780
2.2		Axle loadings, laden front/rear		kg	8590/1050 ¹⁾	8610/1160 ¹⁾	
2.3		Axle loadings, unladen front/rear		kg	2380/3270	2400/3380	
Tyres, chassis	3.1	Tyres - pneumatic (P), pneumatic shaped cushion (SE), solid rubber (R)			P	P	
	3.2	Tyre size - front			250-15-16PR(I)	250-15-16PR(I)	
	3.3	Tyre size - rear			7.00-12-12PR(I)	7.00-12-12PR(I)	
	3.5	Wheels - number front/rear (x = driven wheels)			2x/2	2x/2	
	3.6	Tread - front	b ₁₀	mm	1115	1115	
	3.7	Tread - rear	b ₁₁	mm	1090	1090	
	Dimensions	4.1	Tilt of mast/fork carriage forward/backward	α/β	deg	6/12	6/12
4.2		Height, mast lowered	h ₁	mm	2110	2110	
4.3		Free lift	h ₂	mm	110	110	
4.4		Lift	h ₃	mm	3000	3000	
4.5		Height, mast extended	h ₄	mm	4220	4220	
4.7		Height of overhead guard	h ₆	mm	2190	2190	
4.8		Seat height	h ₇	mm	1110	1110	
4.12		Coupling height	h ₁₀	mm	370	370	
4.19		Overall length	l ₁	mm	3995	3995	
4.20		Length to face of forks	l ₂	mm	2925	2925	
4.21		Overall width	b ₁	mm	1350	1350	
4.22		Fork dimensions	s/e/l	mm	50/140/1070	50/140/1070	
4.23		Fork carriage DIN 15 173, class/type A,B			III	III	
4.24		Fork carriage width	b ₃	mm	1170	1170	
4.31		Ground clearance, laden, below mast	m ₁	mm	140	140	
4.32		Ground clearance, centre of wheelbase	m ₂	mm	190	190	
4.33		Aisle width for pallets 1000x1200 wide*	A _{st}	mm	4320	4320	
4.34	Aisle width for pallets 800x1200 long*	A _{sl}	mm	4520	4520		
4.35	Turning radius	W _a	mm	2600	2600		
4.36	Internal turning radius	b ₁₃	mm	840	840		
Performance	5.1	Travel speed, laden/unladen		km/h	24/24.5	24/24	
	5.2	Lift speed, laden/unladen		m/s	0.51/0.55	0.51/0.55	
	5.3	Lowering speed, laden/unladen		m/s	0.50/0.55	0.50/0.55	
	5.6	Max. drawbar pull, laden/unladen		N	35300/13700	35300/13700	
	5.7	Gradeability, laden ²⁾		%	38	39	
	5.8	Max. gradeability, laden/unladen ³⁾		%	42/22	43/21	
	5.9	Acceleration time, laden/unladen		s			
	5.10	Service brake			hydraulic	hydraulic	
	Engine	7.1	Engine manufacturer/type			TOYOTA 1FZ	TOYOTA 14Z
		7.2	Engine power acc to ISO 1585		kW	62	56
7.3		Rated speed		1/min	2100	2100	
7.4		No. of cylinders/displacement		cm ³	6/4476	6/5204	
7.5		Fuel consumption acc to VDI cycle		l/h			
Others	8.2	Operating pressure for attachments		bar	181	181	
	8.3	Oil volume for attachments		l/min	95	98	
	8.4	Sound level at the driver's ear according to EN 12 053		dB(A)	82	83	
	8.5	Towing coupling, type DIN					

* aisle width calculation based on VDI 2198

¹⁾ With 600 mm load center: 7FG35 = 8010/1140 mm; 7FD35 = 8030/1250 mm

²⁾ At 1,5km/h

³⁾ Computed values

DIMENSIONAL DRAWINGS

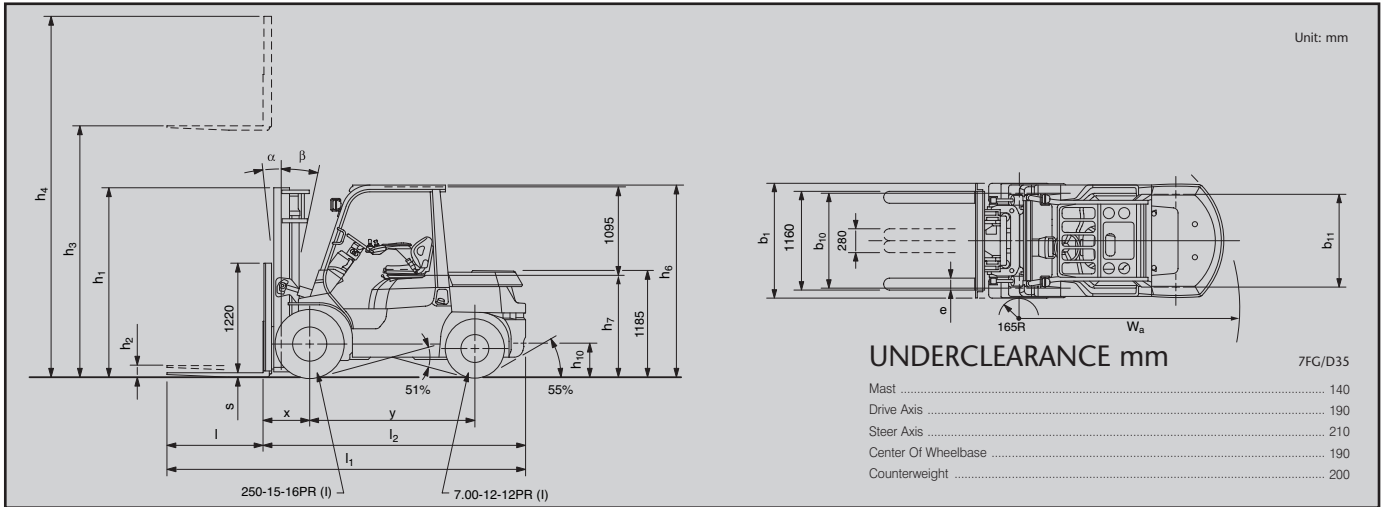

SPECIAL TREAD

Model	7FG/7FD35		
Front Tyre Single/Dual	Single	Single	Dual
Front Tyre Size	250-15-16PR (l)	28x12.5-15-18PR (l)	28x8-15-12PR (l)
Overall Width	mm 1350	1450	1690
Tread, Front	mm 1155	1150	1260

MAST SPECIFICATION & RATED CAPACITIES

Model	Mast Type	Maximum Fork Height h_3	Overall Height		Free Lift		Single Tyre			Dual Tyre		
			Lowered h_1	Extended Without Load Backrest h_4	Without Load Backrest h_2	With Standard Load Backrest h_2	Tilt Range		Load Capacity at 500 mm [600mm] LCP kg	Tilt Range		Load Capacity at 500 mm [600mm] LCP kg
							FWD	BWD		FWD	BWD	
		mm	mm	mm	mm	mm	deg	deg	kg	deg	deg	kg
7FG/D35	V	3000	2110 <2200>	3800	110	110	6	12	4000 [3500]	6	12	4000 [3500]
		3300	2290 <2350>	4100	110	110	6	12	4000 [3500]	6	12	4000 [3500]
		3500	2390 <2450>	4300	110	110	6	12	4000 [3500]	6	12	4000 [3500]
		3700	2490 <2600>	4500	110	110	6	12	4000 [3500]	6	12	4000 [3500]
		4000	2740 <2800>	4800	110	110	6	12	4000 [3500]	6	12	4000 [3500]
		4500	2990 <3050>	5300	110	110	6	12	4000 [3500]	6	12	4000 [3500]
	FV	5000	3240 <3300>	5800	110	110	6	6	<3800 [3500]> <3700 [3450]>	6	12	3800 [3500]
		3000	2110	3830	1280	890	6	12	4000 [3500]	6	12	4000 [3500]
		3300	2290	4130	1460	1070	6	12	4000 [3500]	6	12	4000 [3500]
		3500	2390	4330	1560	1170	6	12	4000 [3500]	6	12	4000 [3500]
		3700	2490	4530	1660	1270	6	12	4000 [3500]	6	12	4000 [3500]
		4000	2740	4830	1910	1520	6	12	4000 [3500]	6	12	4000 [3500]
	FSV	3700	1890	4530	1060	670	6	6	4000 [3500]	6	6	4000 [3500]
		4000	1990	4830	1160	770	6	6	4000 [3500]	6	6	4000 [3500]
		4300	2110	5130	1280	890	6	6	3800 [3500]	6	6	3800 [3500]
		4500	2225	5330	1395	1005	6	6	3700 [3500]	6	6	3700 [3500]
		4700	2290	5530	1460	1070	6	6	3700 [3500]	6	6	3700 [3500]
		5000	2390	5830	1560	1170	6	6	3600 [3400]	6	6	3600 [3400]
5500	2540	6330	1710	1320	6	6	3000 [2800]	6	6	3500 [3300]		
6000	2740	6830	1910	1520	6	6	2200 [2100]	6	6	3400 [3200]		

Note: Height of standard load backrest is 1220 mm; h_4 for standard load backrest is +420 mm (V), +390 mm (FV), +390 mm (FSV)
 Data between "<" ">" is for heavy-duty mast
 Lower fork heights available.

4,000 - 5,000 kg, at 600 mm LCP

MAIN VEHICLE SPECIFICATIONS

				TOYOTA	TOYOTA	TOYOTA	TOYOTA	TOYOTA	TOYOTA	
Characteristics	1.1	Manufacturer		TOYOTA	TOYOTA	TOYOTA	TOYOTA	TOYOTA	TOYOTA	
	1.2	Model		02-7FG40	42-7FD40	02-7FG45	42-7FD45	02-7FGA50	42-7FDA50	
	1.3	Power		gasoline	diesel	gasoline	diesel	gasoline	diesel	
	1.4	Operator Type		rider seated	rider seated	rider seated	rider seated	rider seated	rider seated	
	1.5	Load capacity/rated load	Q	kg	4500 [4000]	4500 [4000]	5000 [4500]	5000 [4500]	5000	5000
	1.6	Load centre	c	mm	500 [600]	500 [600]	500 [600]	500 [600]	600	600
	1.8	Load distance, centre of drive axle to fork	x	mm	555	555	575	575	570	570
	1.9	Wheelbase	y	mm	2000	2000	2000	2000	2000	2000
	Weight	2.1	Truck weight ¹⁾		kg	6220	6350	6610	6770	7230
2.2		Axle loadings, laden front/rear		kg	9570/1150 ²⁾	9600/1250 ¹⁾	10480/1130 ³⁾	10540/1230 ³⁾	10970/1260	11040/1350
2.3		Axle loadings, unladen front/rear		kg	2680/3540	2710/3640	2740/3870	2800/3970	3050/4180	3110/4280
Tyres, chassis	3.1	Tyres - pneumatic (P), pneumatic shaped cushion (SE), solid rubber (R)			P	P	P	P	P	P
	3.2	Tyre size - front			300-15-18PR(I)	300-15-18PR(I)	300-15-18PR(I)	300-15-18PR(I)	300-15-18PR(I)	300-15-18PR(I)
	3.3	Tyre size - rear			7.00-12-12PR(I)	7.00-12-12PR(I)	7.00-12-12PR(I)	7.00-12-12PR(I)	7.00-12-14PR(I)	7.00-12-14PR(I)
	3.5	Wheels - number front/rear (x = driven wheels)			2x/2	2x/2	2x/2	2x/2	2x/2	2x/2
	3.6	Tread - front	b ₁₀	mm	1150	1150	1150	1150	1150	1150
	3.7	Tread - rear	b ₁₁	mm	1090	1090	1090	1090	1150	1150
	Dimensions	4.1	Tilt of mast/fork carriage forward/backward	α/β	deg	6/12	6/12	6/12	6/12	6/12
4.2		Height, mast lowered	h ₁	mm	2110	2110	2200	2200	2450	2450
4.3		Free lift	h ₂	mm	115	115	115	115	120	120
4.4		Lift	h ₃	mm	3000	3000	3000	3000	3000	3000
4.5		Height, mast extended	h ₄	mm	4220	4220	4220	4220	4370	4370
4.7		Height of overhead guard	h ₆	mm	2285	2285	2285	2285	2285	2285
4.8		Seat height	h ₇	mm	1205	1205	1205	1205	1205	1205
4.12		Coupling height	h ₁₀	mm	370	370	370	370	370	370
4.19		Overall length	l ₁	mm	4135	4135	4200	4200	4390	4390
4.20		Length to face of forks	l ₂	mm	3065	3065	3130	3130	3170	3170
4.21		Overall width	b ₁	mm	1450	1450	1450	1450	1450	1450
4.22		Fork dimensions	s/e/l	mm	55/140/1070	55/140/1070	55/140/1070	55/140/1070	63/150/1220	63/150/1220
4.23		Fork carriage DIN 15 173, class/type A,B			III	III	III	III	IV	IV
4.24		Fork carriage width	b ₃	mm	1170	1170	1170	1170	1170	1170
4.31		Ground clearance, laden, below mast	m ₁	mm	140	140	140	140	140	140
4.32		Ground clearance, centre of wheelbase	m ₂	mm	280	280	280	280	285	285
4.33		Aisle width for pallets 1000x1200 wide*	A _{st}	mm	4455	4455	4525	4525	4570	4570
4.34	Aisle width for pallets 800x1200 long*	A _{sl}	mm	4655	4655	4725	4725	4770	4770	
4.35	Turning radius	W _a	mm	2700	2700	2750	2750	2800	2800	
4.36	Internal turning radius	b ₁₃	mm	880	880	880	880	880	880	
Performance	5.1	Travel speed, laden/unladen		km/h	24/24.5	23.5/24	23.5/24	23.5/24	23.5/24	23.5/24
	5.2	Lift speed, laden/unladen		m/s	0.51/0.55	0.51/0.55	0.44/0.48	0.48/0.52	0.44/0.48	0.48/0.52
	5.3	Lowering speed, laden/unladen		m/s	0.50/0.55	0.50/0.55	0.50/0.50	0.50/0.50	0.50/0.50	0.50/0.50
	5.6	Max. drawbar pull, laden/unladen		N	36300/15700	36300/15700	36300/16700	36300/16700	36300/17600	36300/17600
	5.7	Gradeability, laden ²⁾		%	34	35	30	32	28	29
	5.8	Max. gradeability, laden/unladen ³⁾		%	38/22	39/22	34/22	35/22	31/22	32/22
	5.9	Acceleration time, laden/unladen		s						
5.10	Service brake				hydraulic	hydraulic	hydraulic	hydraulic	hydraulic	
Engine	7.1	Engine manufacturer/type			TOYOTA 1FZ	TOYOTA 14Z	TOYOTA 1FZ	TOYOTA 14Z	TOYOTA 1FZ	TOYOTA 14Z
	7.2	Engine power acc to ISO 1585		kW	62	56	62	56	62	56
	7.3	Rated speed		1/min	2100	2100	2100	2100	2100	2100
	7.4	No. of cylinders/displacement		cm ³	6/4476	6/5204	6/4476	6/5204	6/4476	6/5204
	7.5	Fuel consumption acc to VDI cycle		l/h						
Others	8.2	Operating pressure for attachments		bar	181	181	181	181	181	181
	8.3	Oil volume for attachments		l/min	95	98	95	106	95	106
	8.4	Sound level at the driver's ear according to EN 12 053		dB(A)	82	83	82	83	82	83
	8.5	Towing coupling, type DIN								

* aisle width calculation based on VDI 2198

¹⁾ With 600 mm load center: 7FG40 = 8990/1230 mm; 7FD40 = 9020/1330 mm; 7FG45 = 9880/1230 mm; 7FD45 = 9940/1330 mm

²⁾ At 1,5km/h

³⁾ Computed values

7FG/D40, 7FG/D45, 7FG/DA50

DIMENSIONAL DRAWINGS

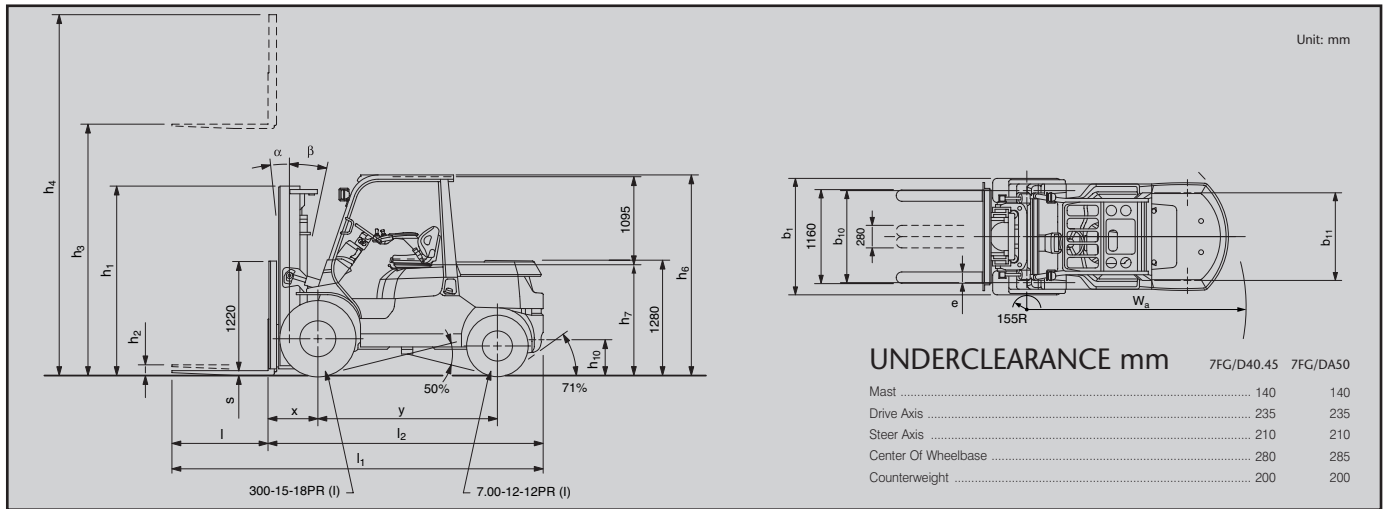

SPECIAL TREAD

Model	7FG/7FD40			7FG/7FD45 & 7FGA/7FDA50		
Front Tyre Single/Dual	Single	Single	Dual	Single	Single	Dual
Front Tyre Size	300-15-18PR (I)	32x12.1-15-20PR (I)	8.25-15-12PR (I)	300-15-18PR (I)	32x12.1-15-20PR (I)	8.25-15-12PR (I)
Overall Width	mm 1450	1465	1890	1445	1465	1890
Tread, Front	mm 1150	1150	1385	1150	1150	1385

MAST SPECIFICATION & RATED CAPACITIES

Model	Mast Type	Maximum Fork Height	Overall Height		Free Lift		Single Tyre			Dual Tyre		
			Lowered	Extended Without Load Backrest	Without Load Backrest	With Standard Load Backrest	Tilt Range		Load Capacity at 500 mm [600mm] LCP	Tilt Range		Load Capacity at 500 mm [600mm] LCP
							FWD	BWD		FWD	BWD	
			h ₃	h ₁	h ₄	h ₂	deg	deg	kg	deg	deg	kg
7FG/D40	V	3000	2110 <2200>	3795	115	115	6	12	4500 [4000]	6	12	4500 [4000]
		3300	2290 <2350>	4095	115	115	6	12	4500 [4000]	6	12	4500 [4000]
		3500	2390 <2450>	4295	115	115	6	12	4500 [4000]	6	12	4500 [4000]
		3700	2490 <2600>	4495	115	115	6	12	4500 [4000]	6	12	4500 [4000]
		4000	2740 <2800>	4795	115	115	6	12	4500 [4000]	6	12	4500 [4000]
		4500	2990 <3050>	5295	115	115	6	12	4500 [4000]	6	12	4500 [4000]
	FV	5000	3240 <3300>	5795	115	115	6	6	4200 [4000]	6	12	4400 [4000]
		3000	2110	3825	1285	895	6	12	4500 [4000]	6	12	4500 [4000]
		3300	2290	4125	1465	1075	6	12	4500 [4000]	6	12	4500 [4000]
		3500	2390	4325	1665	1175	6	12	4500 [4000]	6	12	4500 [4000]
		3700	2490	4525	1865	1275	6	12	4500 [4000]	6	12	4500 [4000]
		4000	2740	4825	1915	1525	6	12	4500 [4000]	6	12	4500 [4000]
FSV	3700	1890	4525	1065	675	6	6	4500 [4000]	6	6	4500 [4000]	
	4000	1990	4825	1165	775	6	6	4500 [4000]	6	6	4500 [4000]	
	4300	2110	5125	1285	895	6	6	4500 [4000]	6	6	4500 [4000]	
	4500	2225	5325	1400	1010	6	6	4500 [4000]	6	6	4500 [4000]	
	4700	2290	5525	1465	1075	6	6	4500 [4000]	6	6	4500 [4000]	
	5000	2390	5825	1565	1175	6	6	4400 [4000]	6	6	4400 [4000]	
7FG/D45	V	5500	2540	6325	1715	1325	6	6	3500 [3500]	6	6	4200 [4000]
		6000	2740	6825	1915	1525	6	6	2700 [2700]	6	6	3300 [3000]
		3000	2200	3670	115	115	6	12	5000 [4500]	6	12	5000 [4500]
		3300	2350	3970	115	115	6	12	5000 [4500]	6	12	5000 [4500]
		3500	2450	4170	115	115	6	12	5000 [4500]	6	12	5000 [4500]
		3700	2600	4370	115	115	6	12	5000 [4500]	6	12	5000 [4500]
	FV	4000	2800	4670	115	115	6	12	5000 [4500]	6	12	5000 [4500]
		4500	3050	5170	115	115	6	6	5000 [4500]	6	12	5000 [4500]
		5000	3300	5670	115	115	6	6	4000 [4000]	6	12	4600 [4400]
		3000	2200	3700	1500	980	6	12	5000 [4500]	6	12	5000 [4500]
		3300	2350	4000	1650	1130	6	12	5000 [4500]	6	12	5000 [4500]
		3500	2450	4200	1750	1230	6	12	5000 [4500]	6	12	5000 [4500]
FSV	3700	2600	4400	1900	1380	6	12	5000 [4500]	6	12	5000 [4500]	
	4000	2800	4700	2100	1580	6	12	5000 [4500]	6	12	5000 [4500]	
	4300	2050	4400	1350	830	6	6	5000 [4500]	6	6	5000 [4500]	
	4500	2120	4700	1420	900	6	6	5000 [4500]	6	6	5000 [4500]	
	4700	2200	5000	1500	980	6	6	4900 [4500]	6	6	4900 [4500]	
	5000	2270	5200	1570	1050	6	6	4500 [4200]	6	6	4700 [4400]	
7FG/D50	V	4700	2350	5400	1650	1130	6	6	4500 [4200]	6	6	4700 [4400]
		5000	2450	5700	1750	1230	6	6	4000 [4000]	6	6	4600 [4300]
		5500	2600	6200	1900	1380	6	6	3000 [3000]	6	6	4400 [4100]
		6000	2800	6700	2100	1580	6	6	2300 [2300]	6	6	4200 [3900]
		3000	2450	3845	120	120	6	12	5000	6	12	5000
		3300	2600	4145	120	120	6	12	5000	6	12	5000
	FSV	3500	2800	4345	120	120	6	12	4900	6	12	5000
		3700	2800	4545	120	120	6	12	5000	6	12	5000
		4000	3050	4845	120	120	6	12	5000	6	12	5000
		4500	3300	5345	120	120	6	6	5000	6	12	5000
		5000	3550	5845	120	120	6	6	4000	6	12	4800
		3700	2200	4570	1330	830	6	6	5000	6	6	5000
FSV	4000	2270	4870	1400	900	6	6	4900	6	6	4900	
	4300	2350	5170	1480	980	6	6	4800	6	6	4800	
	4700	2450	5570	1580	1080	6	6	4300	6	6	4600	
	5000	2600	5870	1730	1230	6	6	4100	6	6	4500	
	5500	2800	6370	1930	1430	6	6	3100	6	6	4300	
	6000	3050	6870	2180	1680	6	6	2400	6	6	4100	

Note: Height of standard load backrest is 1220 mm (7FG/D40.45); 1370 (7FG/DA50);
 h₄ with standard load backrest is + 425/550/525 mm (7FG/D40/45/50 V), + 395/520 mm (7FG/D40/45 FV), + 395/520/500 mm (7FG/D40/45/50 FSV)
 Data between "<" ">" is for heavy-duty mast

7FGF15.18.20.25.30, 7FGJF35
7FDF15.18.20.25.30, 7FDJF35

- Toyota SAS (System of Active Stability*)
- Toyota OPS (Operator Presence Sensing)
- Toyota OTC (Operator Total Care):
 - Toyota ORS (Operator Restraint System) seat
 - Seat mounted minilevers (optional)
 - D2 pedal (optional)
- Wide visible mast [MFH: 3000 mm]
- Load backrest [Height: 1220 mm]
- Long forks [Length: 1000 mm]
- Long forkbar [Length: 920 mm (7FG/DF15.18); 1020 mm (7FG/DF20.25); 1070 mm (7FG/DF30, 7FG/DJF35)]
- 3-way valve (A400)
- Dual brake system
- Pneumatic tyres
- Full hydraulic power steering
- 7" cyclone air cleaner with snorkel air intake
- Anti-restart ignition key switch
- Headlights
- Rear combination lights
- Integrated monitoring center
- Memory tilt steering column

7FG35.40.45, 7GA50
7FD35.40.45, 7DA50

- Toyota SAS (System of Active Stability*)
- Toyota OPS (Operator Presence Sensing)
- Toyota OTC (Operator Total Care):
 - Toyota ORS (Operator Restraint System) seat
 - Seat mounted minilevers (optional)
 - D2 pedal (optional)
- Wide visible mast [MFH: 3000 mm]
- Load backrest [Height: 1220 mm (7FG/D35.40.45); 1370 mm (7FG/DA50)]
- Long forks [Length: 1070 mm (7FG/D35.40.45); 1220 mm (7FG/DA50)]
- Long forkbar [Length: 1170 mm]
- 2-way valve
- Dual brake system
- Pneumatic tyres
- Full hydraulic power steering
- 8" cyclone air cleaner with snorkel air intake
- Headlights
- Integrated monitoring center
- Memory tilt steering column

NOTE: * When dual tyres are selected, the Active Control Rear Stabilizer function of the SAS system of Active Stability (SAS) is not included.

The data in this spec sheet was determined based on our standard testing condition. Operating performance may vary depending on the actual specification and condition of the truck as well as the condition of the operating area. Availability and specifications are determined regionally and are subject to change without notice. Please consult your Toyota representative for details.