

# IC-PNEUMATIC

Diesel or LPG engine  
Pneumatic Tires

CMP50  
CMP60  
CMP70  
CMP75s

5000 kg  
6000 kg  
7000 kg  
7500 kg

## CMP50/60/70/75s



**THE FORKLIFT**

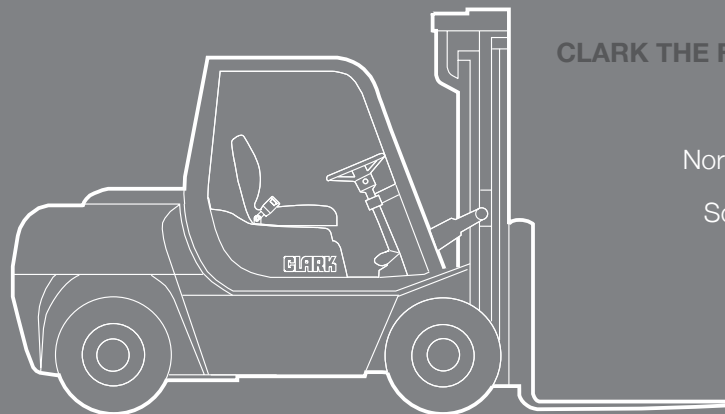

**CLARK THE FORKLIFT**

Europe

North America

South Korea

[www.clarkmheu.com](http://www.clarkmheu.com)

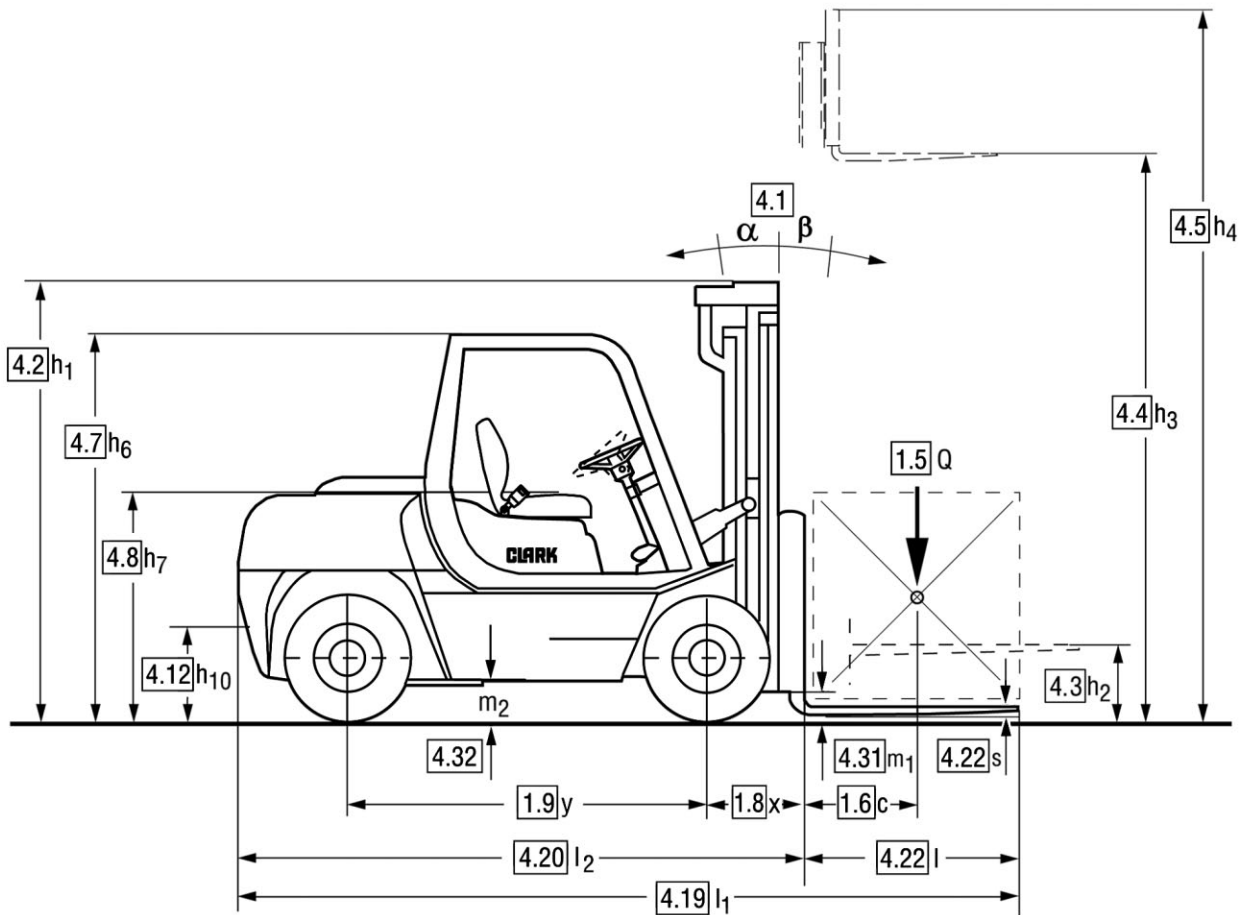

# CMP50/60/70/75s

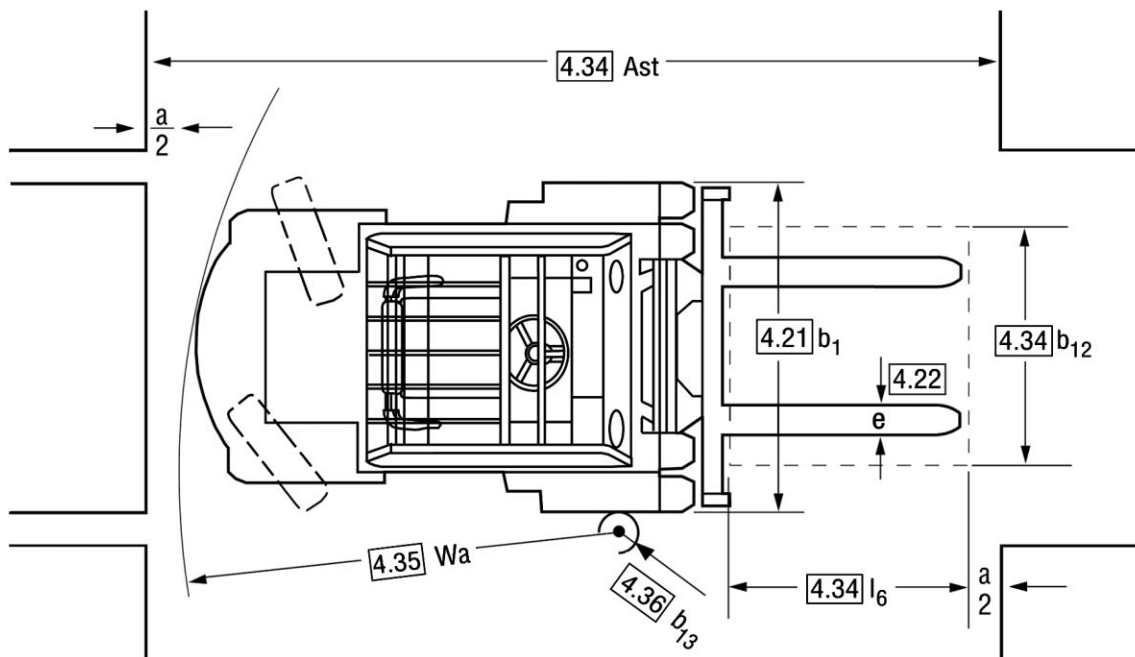

$$A_{st} = W_a + x + l_6 + a$$

a = 200 mm (safety distance)

For corresponding data see Specification Chart.

## Truck Capacities

Capacity at different load centres

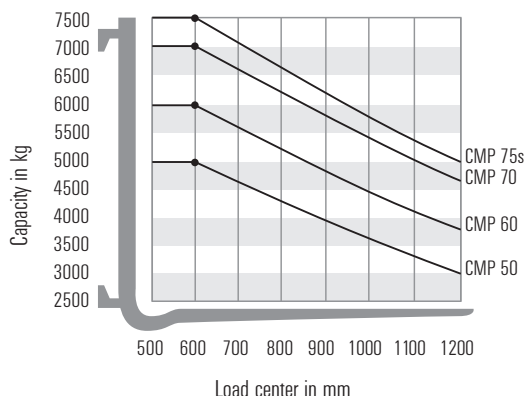

**Note:**

The listed capacities are valid only for the standard upright in vertical position with standard fork carriage and standard forks, up to max. lifting height of 3500 mm CMP 50-75s. The centre of gravity of the load may be displaced by max. 100 mm against the longitudinal centre line of the truck. Load centre is determined from top and front face of forks. The values are based on a 1000 mm cube load configuration with the centre of gravity at the true centre of the cube. With upright tilted forward lower capacity values are valid. Attachments, longer forks, exceptional load dimensions and higher lifting heights may reduce the capacity. Please contact your CLARK dealer if you require further information.

## Upright table

Capacity at different load centres

**Upright table metrics in mm**

CLARK Ref	max. fork height h3	overall height lowered h1	overall height raised h4*	free lift h2
-----------	---------------------	---------------------------	---------------------------	--------------

**Standard CMP 50, 60, 70, 75s L/D**

(2 Stage Mast, standard free lift)

V	2500	2250	3720	110
V	2700	2350	3920	110
V	3000	2500	4220	110
V	3300	2650	4520	110
V	3500	2750	4720	110
V	3700	2850	4920	110
V	4000	3000	5220	110
V	4500	3250	5720	110
V	5000	3500	6220	110
V	5500	3750	6720	110
V	6000	4200	7220	110
V	6400	4400	7620	110

\* without LBR

**Upright table metrics in mm**

CLARK Ref	max. fork height h3	overall height lowered h1	overall height raised h4*	free lift h2
-----------	---------------------	---------------------------	---------------------------	--------------

**Triple CMP 50, 60, 70, 75s L/D**

(3 Stage Mast, full free lift)

M	4000	2410	5170	1240
M	4500	2580	5670	1410
M	4900	2715	6070	1540
M	6200	3272	7370	2100
M	7000	3540	8170	2365
M	8000	3875	9170	2695

\* without LBR

# LPG engine

according to VDI 2198

All values shown are for standard lift truck with standard equipment. If the truck is supplied with options, values may change. All values given may vary +5% and -10% due to the motor and system tolerances and represent nominal values obtained under typical operating conditions. Specifications for Non-emission limited truck.

# SPECIFICATIONS

1.1 Manufacture (Abbreviation)		CLARK	CLARK	CLARK	CLARK	
Characteristics	1.2 Manufacture's designation	<b>CMP 50 L</b>	<b>CMP 60 L</b>	<b>CMP 70 L</b>	<b>CMP 75s L</b>	
	1.3 Drive Unit Diesel, L.P. Gas	L.P.-Gas	L.P.-Gas	L.P.-Gas	L.P.-Gas	
	1.4 Operator type stand on / driver seated	driver seated	driver seated	driver seated	driver seated	
	1.5 Load Capacity / rated load Q (t)	5,0	6,0	7,0	7,5	
	1.6 Load Center distance c (mm)	600	600	600	600	
	1.8 Load Center distance, centre of drive axle to fork face x (mm)	630	630	630	630	
	1.9 Wheelbase y (mm)	2200	2200	2200	2200	
	Weight	2.1 Service weight kg	8350	8910	9530	9725
		2.2 Axle loading, laden front / rear kg	11855/1495	13295/1615	14725/1805	15655/1970
2.3 Axle loading, unladen front / rear kg		4060/4290	3940/4970	3810/5720	3970/5755	
Tires, Chassis	3.1 Tire type, P=pneumatic, SE=superelastic, C=cushion 1)	P	P	P	P	
	3.2 Tire size, front	8.25 x 15-14PR	8.25 x 15-14PR	8.25 x 15-14PR	8.25 x 15-14PR	
	3.3 Tire size, rear	8.25 x 15-14PR	8.25 x 15-14PR	8.25 x 15-14PR	8.25 x 15-14PR	
	3.5 Wheels, number front / rear (x=drive wheels)	4x/2	4x/2	4x/2	4x/2	
	3.6 Tread, front b <sub>10</sub> (mm)	1580	1580	1580	1580	
	3.7 Tread, rear b <sub>11</sub> (mm)	1495	1495	1495	1495	
	Dimensions	4.1 Tilt of upright / fork carriage, α/β deg	10/15	10/15	10/15	10/15
4.2 Height, upright lowered h <sub>1</sub> (mm)		2650	2650	2650	2650	
4.3 Freelif h <sub>2</sub> (mm)		110	110	110	110	
4.4 Lift height 3) h <sub>3</sub> (mm)		3300	3300	3300	3300	
4.5 Height upright extended 8) h <sub>4</sub> (mm)		4520	4520	4520	4520	
4.7 Height overheadguard (cab): Std / Container h <sub>6</sub> (mm)		2360	2360	2360	2360	
4.8 Seat high h <sub>7</sub> (mm)		-	-	-	-	
4.12 Coupling high h <sub>10</sub> (mm)		-	-	-	-	
4.19 Overall length l <sub>1</sub> (mm)		4690	4750	4810	4810	
4.20 Length to face of forks l <sub>2</sub> (mm)		3470	3530	3590	3590	
4.21 Width 2) b <sub>1</sub> /b <sub>2</sub> (mm)		2115	2115	2115	2115	
4.22 Fork dimensions s/e/l (mm)		60 x 150 x 1220	60 x 150 x 1220	60 x 150 x 1220	60 x 180 x 1220	
4.23 Fork carriage DIN 15173, A, B		-	-	-	-	
4.24 Fork carriage width b <sub>3</sub> (mm)		2040	2040	2040	2040	
4.31 Ground clearance minimum, unladen 7) m <sub>1</sub> (mm)		205	205	205	205	
4.32 Ground clearance center of wheelbase 7) m <sub>2</sub> (mm)		254	254	254	254	
4.34 Stacking aisle for pallets 800x1200 (l <sub>6</sub> -b <sub>12</sub> )		4990	5040	5100	5100	
4.34 Stacking aisle for pallets 1000x1200 (l <sub>6</sub> -b <sub>12</sub> ) A <sub>st</sub> (mm)		5190	5240	5300	5300	
4.34 Stacking aisle for pallets 1200x800 (l <sub>6</sub> -b <sub>12</sub> ) A <sub>st</sub> (mm)		5390	5440	5500	5500	
4.35 Turning radius W <sub>a</sub> (mm)	3360	3410	3470	3470		
4.36 Internal turning radius 2) b <sub>13</sub> (mm)	-	-	-	-		
Performance	5.1 Travel speed laden/unladen km/h	25,6/27,6	25,3/27,5	25,0/27,4	24,7/27,3	
	5.2 Lift speed laden/unladen m/s	0,40/0,47	0,39/0,47	0,34/0,42	0,30/0,42	
	5.3 Lowering speed laden/unladen m/s	0,40/0,36	0,40/0,36	0,40/0,35	0,40/0,35	
	5.6 Max. drawbar pull laden/unladen 5) N	63484/24049 (57340/19368)	64033/23343 (57555/18633)	64572/22579 (57781/17848)	64611/23137 (58006/17064)	
	5.8 Max. gradeability laden 4) /unladen 5) %	50,2/23,6 (36,1/23,5)	48,5/21,5 (34,9/21,4)	43,3/19,2 (33,7/19,4)	43,0/19,5 (32,5/19,7)	
	5.9 Acceleration time laden/unladen (0 - 15 m) s	-/-	-/-	-/-	-/-	
	5.10 Service brake	hydraulic	hydraulic	hydraulic	hydraulic	
Drive Line	7.1 Manufacturer / Type	GM/4.3 V6	GM/4.3 V6	GM/4.3 V6	GM/4.3 V6	
	7.2 Rated output acc. DIN 70 020 kW	62,4	62,4	62,4	62,4	
	7.3 Rated speed acc. DIN 70 020 min <sup>-1</sup>	2600	2600	2600	2600	
	7.4 No. of cylinders / displacement /cm <sup>3</sup>	6/4294	6/4294	6/4294	6/4294	
	7.5 Fuel consumption acc. VDI-Cycles Diesel=l/h, L.P.Gas=kg/h	-	-	-	-	
Miscellaneous	8.1 Type of control	hydrodyn.	hydrodyn.	hydrodyn.	hydrodyn.	
	8.2 Operating pressure for attachments bar	140	140	140	140	
	8.3 Oil volume for attachments l/min	-	-	-	-	
	8.4 Sound level, driver's ear 6) dB (A)	81	81	81	81	
	8.5 Towing coupling, class/type DIN	-	-	-	-	

1) Optional solid tires 2) Brackets for dual drive 3) For further lift heights, see upright table 4) Laden at 1.6 kph 5) Unladen at μ = 0.9

6) Equivalent permanent sound-pressure level L<sub>pAeq,T</sub> in accordance with DIN EN 12053 7) Listed values can change with other tires and uprights 8) Without LBR

## Diesel engine

according to VDI 2198

All values shown are for standard lift truck with standard equipment. If the truck is supplied with options, values may change. All values given may vary +5% and -10% due to the motor and system tolerances and represent nominal values obtained under typical operating conditions. Specifications for Non-emission limited truck.

# SPECIFICATIONS

1.1 Manufacture (Abbreviation)		CLARK	CLARK	CLARK	CLARK
Characteristics	1.2 Manufacture's designation	<b>CMP 50 D</b>	<b>CMP 60 D</b>	<b>CMP 70 D</b>	<b>CMP 75s D</b>
	1.3 Drive Unit Diesel, L.P. Gas	Diesel	Diesel	Diesel	Diesel
	1.4 Operator type stand on / driver seated	driver seated	driver seated	driver seated	driver seated
	1.5 Load Capacity / rated load Q (t)	5,0	6,0	7,0	7,5
	1.6 Load Center distance c (mm)	600	600	600	600
	1.8 Load Center distance, centre of drive axle to fork face x (mm)	630	630	630	630
	1.9 Wheelbase y (mm)	2200	2200	2200	2200
Weight	2.1 Service weight kg	8350	8910	9530	9725
	2.2 Axle loading, laden front / rear kg	11855/1495	13295/1615	14725/1805	15655/1970
	2.3 Axle loading, unladen front / rear kg	4060/4290	3940/4970	3810/5720	3970/5755
Tires, Chassis	3.1 Tire type, P=pneumatic, SE=superelastic, C=cushion 1)	L	L	L	L
	3.2 Tire size, front	8.25 x 15-14PR	8.25 x 15-14PR	8.25 x 15-14PR	8.25 x 15-14PR
	3.3 Tire size, rear	8.25 x 15-14PR	8.25 x 15-14PR	8.25 x 15-14PR	8.25 x 15-14PR
	3.5 Wheels, number front / rear (x=drive wheels)	4x/2	4x/2	4x/2	4x/2
	3.6 Tread, front b <sub>10</sub> (mm)	1580	1580	1580	1580
	3.7 Tread, rear b <sub>11</sub> (mm)	1495	1495	1495	1495
	Dimensions	4.1 Tilt of upright / fork carriage, α/β deg	10/15	10/15	10/15
4.2 Height, upright lowered h <sub>1</sub> (mm)		2650	2650	2650	2650
4.3 Freelif h <sub>2</sub> (mm)		110	110	110	110
4.4 Lift height 3) h <sub>3</sub> (mm)		3300	3300	3300	3300
4.5 Height upright extended 8) h <sub>4</sub> (mm)		4520	4520	4520	4520
4.7 Height overheadguard (cab): Std / Container h <sub>6</sub> (mm)		2360	2360	2360	2360
4.8 Seat height h <sub>7</sub> (mm)		-	-	-	-
4.12 Coupling height h <sub>10</sub> (mm)		-	-	-	-
4.19 Overall length l <sub>1</sub> (mm)		4690	4750	4810	4810
4.20 Length to face of forks l <sub>2</sub> (mm)		3470	3530	3590	3590
4.21 Width 2) b <sub>1</sub> /b <sub>2</sub> (mm)		2115	2115	2115	2115
4.22 Fork dimensions s/e/l (mm)		60 x 150 x 1220	60 x 150 x 1220	60 x 150 x 1220	60 x 180 x 1220
4.23 Fork carriage DIN 15173, A, B		-	-	-	-
4.24 Fork carriage width b <sub>3</sub> (mm)		2040	2040	2040	2040
4.31 Ground clearance minimum, unladen 7) m <sub>1</sub> (mm)		205	205	205	205
4.32 Ground clearance center of wheelbase 7) m <sub>2</sub> (mm)		254	254	254	254
4.34 Stacking aisle for pallets 800x1200 (l <sub>6</sub> -b <sub>12</sub> )		4990	5040	5100	5100
4.34 Stacking aisle for pallets 1000x1200 (l <sub>6</sub> -b <sub>12</sub> ) A <sub>st</sub> (mm)	5190	5240	5300	5300	
4.34 Stacking aisle for pallets 1200x800 (l <sub>6</sub> -b <sub>12</sub> ) A <sub>st</sub> (mm)	5390	5440	5500	5500	
4.35 Turning radius W <sub>a</sub> (mm)	3360	3410	3470	3470	
4.36 Internal turning radius 2) b <sub>13</sub> (mm)	-	-	-	-	
Performance	5.1 Travel speed laden/unladen km/h	23,8/25,6	23,5/25,5	23,0/25,5	22,8/25,1
	5.2 Lift speed laden/unladen m/s	0,38/0,42	0,36/0,42	0,34/0,38	0,33/0,38
	5.3 Lowering speed laden/unladen m/s	0,43/0,43	0,43/0,43	0,38/0,38	0,38/0,38
	5.6 Max. drawbar pull laden/unladen 5) N	68865/24049 (60409/19368)	69298/23343 (60605/18633)	70701/22579 (60939/17848)	71273/23137 (61321/18652)
	5.8 Max. gradeability laden 4) /unladen 5) %	48,5/23,6 (43/23,5)	43,2/22,8 (43,2/21,4)	43,1/21,7 (38,9/19,4)	43,2/19,7 (38,7/19,7)
	5.9 Acceleration time laden/unladen (0 - 15 m) s	-/-	-/-	-/-	-/-
	5.10 Service brake	hydraulic	hydraulic	hydraulic	hydraulic
Drive Line	7.1 Manufacturer / Type	Perkins/1104C-42	Perkins/1104C-42	Perkins/1104C-42	Perkins/1104C-42
	7.2 Rated output acc. DIN 70 020 kW	62	62	62	62
	7.3 Rated speed acc. DIN 70 020 min <sup>-1</sup>	2200	2200	2200	2200
	7.4 No. of cylinders / displacement /cm <sup>3</sup>	4/4400	4/4400	4/4400	4/4400
	7.5 Fuel consumption acc. VDI-Cycles Diesel=l/h, L.P.Gas=kg/h	-	-	-	-
Miscellaneous	8.1 Type of control	hydrodyn.	hydrodyn.	hydrodyn.	hydrodyn.
	8.2 Operating pressure for attachments bar	140	140	140	140
	8.3 Oil volume for attachments l/min	-	-	-	-
	8.4 Sound level, driver's ear 6) dB (A)	83	83	83	83
	8.5 Towing coupling, class/type DIN	-	-	-	-

1) Optional solid tires 2) Brackets for dual drive 3) For further lift heights, see upright table 4) Laden at 1.6 kph 5) Unladen at μ = 0.9

6) Equivalent permanent sound-pressure level L<sub>pAeq,T</sub> in accordance with DIN EN 12053 7) Listed values can change with other tires and uprights 8) Without LBR

**CLARK CMP 50/60/70/75s Series** pneumatic tire trucks are designed to provide high levels of reliability through the use of durable components and rugged construction. Suited to demanding applications such as handling building materials and concrete products and in warehousing and stevedoring operations where diesel power, reliable planetary drive axle, and 3-speed transmission provide superior gradeability and durability. Trucks are equipped with CLARK-Hurth 3-speed powershift transmissions and powerful Perkins 1004.42 Series diesel engines. These trucks are supplied with an high level of standard features.

**Operator Control & Comfort**

The CMP 50/75s Series trucks incorporate an isolated operator cell supported on rubber mounts to reduce vibration and sound transmission to the operator seat and controls. Two open steps enable easy access to the cabin. A rubber floor mat makes footing secure. Seat deck-mounted hydraulic control levers reduce fatigue through minimal movement. Forward/backward movement of the electric directional control enables "finger tip" operation of the powershift transaxle; speed range is selected by rotating the grip on the control. Two-pedal inchbrake system provides excellent control and comfort. Left pedal is for inch and brake operation; right pedal for brake only. Durable seat with thick contoured cushions provide excellent support. The seat belt includes a retractor with non-cinching feature. Seat has 6 inches (150 mm) of front-to-back travel to accommodate small and large operators. Rearhinged, clamshell hood with gas cylinder assist makes access for daily inspection convenient. High visibility upright and overhead guard improve operator vision during travel and stacking operations. Operator display monitor includes: Indicator lights for engine oil pressure, battery charge, transmission temperature, park brake "on", turn signal indicators and panel test light. Five-digit hour meter and analog engine temperature gauge and fuel gauge are provided on the display.

**Diesel Engine**

Perkins 1004.42, 4.0L 4-cylinder engines have iron block and cylinder head, 5 main bearing crankshaft and an internal dynamic balancer system that smooths engine vibration. Valve guides, exhaust valve seals and dry type cylinder sleeves are replaceable. New generation design incorporates low smoke, fuel efficient direct fuel injection and manifold type Thermostart system. Vertical exhaust is standard. Engine Accessories/Capacities: Trucks are 12-volt negative ground. Starters are equipped with heavy-duty clutch and anti-restart system. Batteries are 860 CCA at 0°F (-18 °C). All utilize heavy-duty air cleaners with pre-cleaners for added engine protection. Cooling system capacity is 16 qts. (16.9 L). Crankcase capacity is 2 gals. (7.6 L); Fuel tank capacity is 18 gal. (68 L). Service Access: Clamshell hood gives full access for inspections and service. Single piece floorpanel is removable without tools. Filters are easily serviced and located to prevent spillage. Radiator is accessed, and removed easily, without counterweight or major component removal.

**Transmission**

CLARK-Hurth 12000 Series three-speed powershift transmission designed for reliability under maximum load and severe operating conditions. An oil cooler located in the engine radiator extends transmission life. CLARK-Hurth EGS electric shift control provides controlled shift operation and protects the transmission from damage. Mechanical linkage is eliminated. Transmission clutch packs incorporate hydraulic modulation and cushioning systems to smooth engagement and protect internal components under rapid direction reversals. Highly accessible transaxle control, auxiliary gear drive for hydraulic pump and spin-on full-flow lubricant filter simplify service.

**Drive Axle**

A heavy duty ZF planetary drive axle improves tractive effort as maximum wheel torque is developed at the drive wheels, eliminating axlehaft wind-up and reducing loads on other drive components.

**Brakes**

Hydraulic-operated service brakes actuate selfadjusting drum and shoe assemblies at the drive wheels. Brakes can be actuated from either left or right foot pedals. Left foot pedal also provides inching control. Disc/caliper-type parking brake on transmission is left hand-operated, and operator adjustable. Brake system reservoir is easily accessed on the front cowl.

**Steering**

Heavy fabricated steer axle incorporates an integral double-acting steer cylinder providing equal steering rate. Single-piece steer knuckles supported by tapered roller bearings provide high durability with low maintenance requirements. Full hydrostatic operation reduces mechanical links and eliminates kick-back. The axle is mounted in "silent block" cushion mounts that absorb shock and improve comfort. They require no maintenance.

**Hydraulic System**

A single hydraulic pump is transmission driven, providing both durability and accessibility. Full-flow filter is located in the hydraulic tank providing continuous filtration. Hydraulic tank cover incorporates return line fittings, dipstick, and breather filter connection. Adjustable hydraulic valve eliminates unnecessary oil flow, energy loss and heat generation. Integral-with-frame hydraulic tank dissipates hydraulic oil heat. Fluid capacity 29 U.S. gals. (110 L).

**Upright Assembly**

High visibility two-stage designs and are configured to provide maximum forward visibility. Interlocking rail/nested roller upright design utilizes specially rolled inner rail and channel section outer rails for high strength under heavy load conditions and greater tolerance to unbalanced load conditions. Uprights incorporate negative rail drop feature that enables upright rollers to be easily accessed for adjustment. Shaft type fork carriage incorporates six main rollers and four thrust rollers. Tilt cylinders incorporate spherical bushings at their mounting points to extend seal life by maintaining axial cylinder loads. Hydraulic counterbalance valve prevents improper tilt cylinder operation, flow limiting valves protect against rapid carriage descent in the event of a line failure, and a lowering control regulates lowering speeds. Shaft type forks are upset forged and have adjustable fork locks.

**Additional Features/Available Equipment**

Color is high visibility CLARK Green with dark gray operator cell and upright. Wheels are bright white. Operator Manual is permanently attached to truck. Standard features include: recessed towpin, (4) builtin lift eyes, headlights, tail lights, and turn signals. CLARK's Employer's Guide to Material Handling Safety and operator safety video are provided with truck. Available equipment includes: integral sidershifter, steel cab with heater, rear work light, strobe light, audible alarm, mirrors, auxiliary hydraulic functions and attachments. Contact a CLARK representative for additional information.

